



Tightening the
Y-Axis Coupler

Tools Needed:

- Phillips head screwdriver
- 3/32" Allen wrench for split coupler
 - 5/32 Allen wrench for 1/4" to 1/4" coupler
- Loctite or thread locker

Couplers

1/4" - 3/8" Split coupler used on:

- HD500
- HD510
- HD520
- SD120
- SD110
- SD100



1/4" - 1/4" coupler used on machines made prior to 2021:

- HD4 series
- HD3 series
- Piranha FX
- Piranha XL
- HD2 series
 - Mako
 - Black Diamond
- Shark Pro Plus HD
- Shark Pro Plus
- Shark Pro
- Shark
- Slimline



Remove the four Phillips head machine screws holding the motor in place.

- three circled in red and Y-axis homing bolt circled in yellow.

Next, pull the motor away from the gantry leg exposing the coupler and both set screws.

Shark HD5XX machines made after September, 2020 will have a motor and cable that can be separated at the motor for easier disassembly

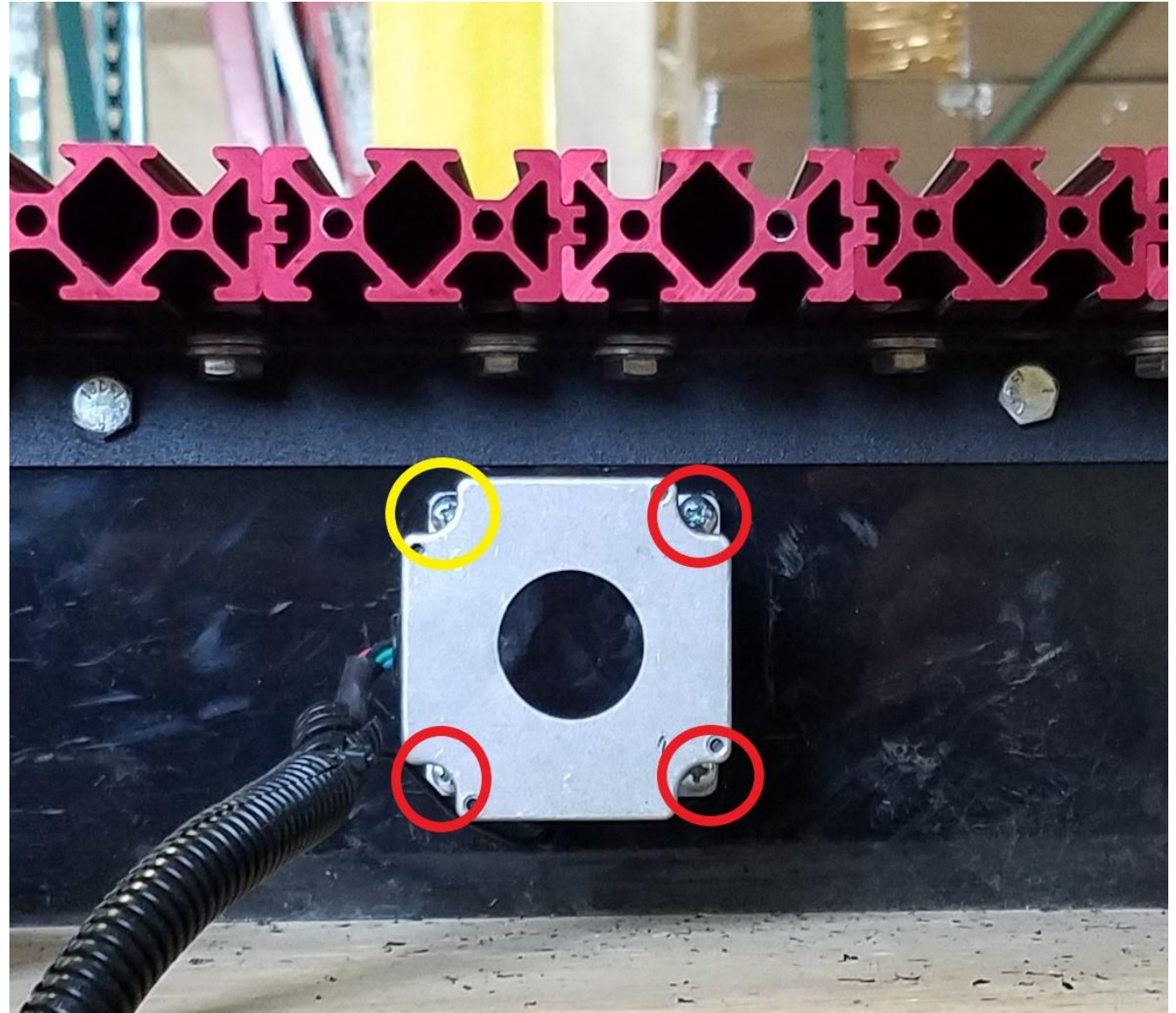

Disassembly

Using a 3/32" Allen wrench, remove the two set screws in the coupler.

- There will be blue non-permanent Loctite on the set screws and will require some force to break the Loctite. Heat should not be needed.

- If heat is needed, we recommend using a heat gun.

Separate the motor and threaded rod from the coupler.

With a wire brush, clean off any Loctite residue from the set screw threads and the coupler.

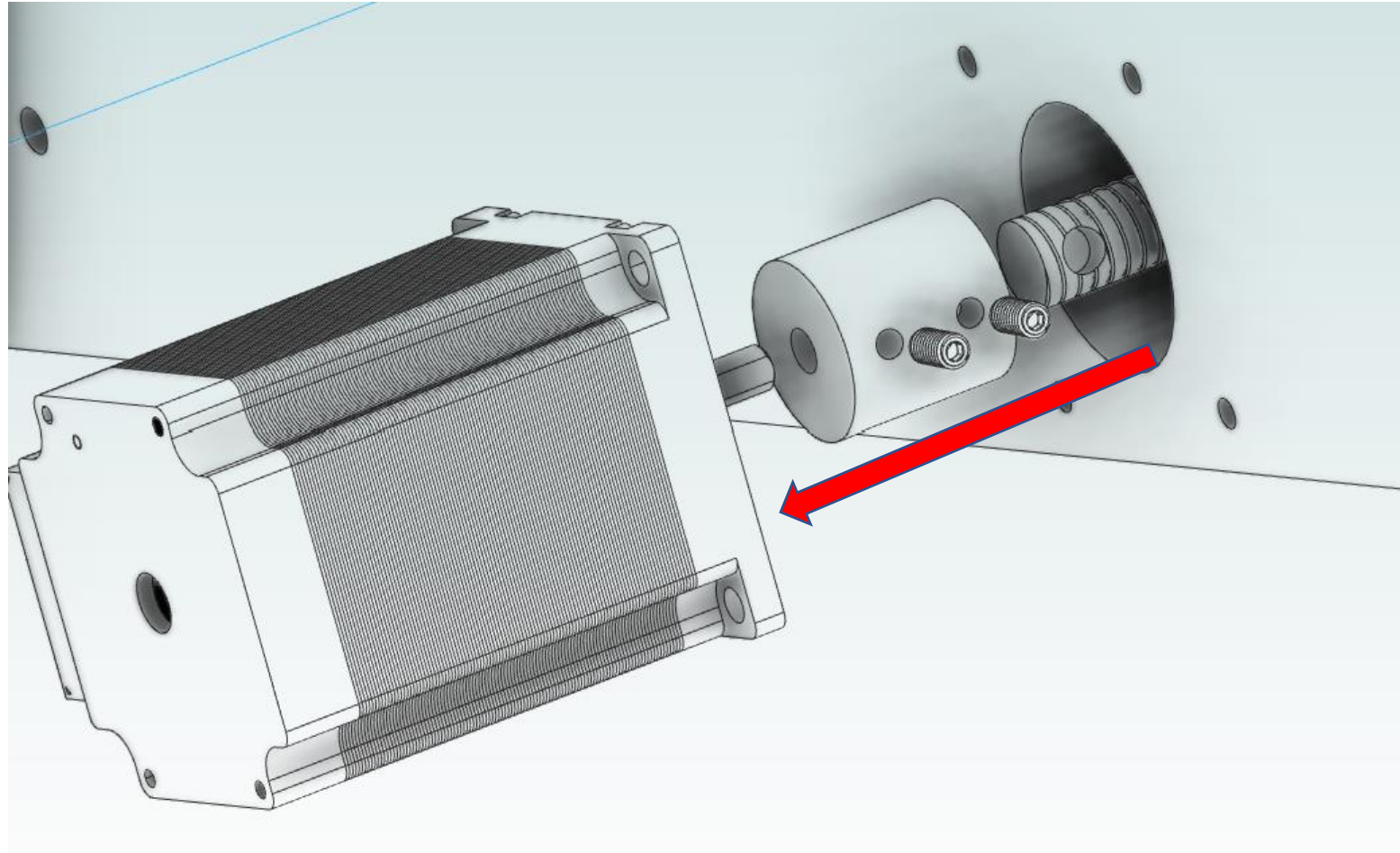

Assembly

Part 1

Align the flat side of the motor shaft to the set screw hole, then insert the motor shaft into the coupler to about half the depth of the coupler.

Apply blue Loctite or non-permanent thread locker onto the set screw.

Tighten the set screw onto the flat side of the motor using the 3/32" Allen wrench.

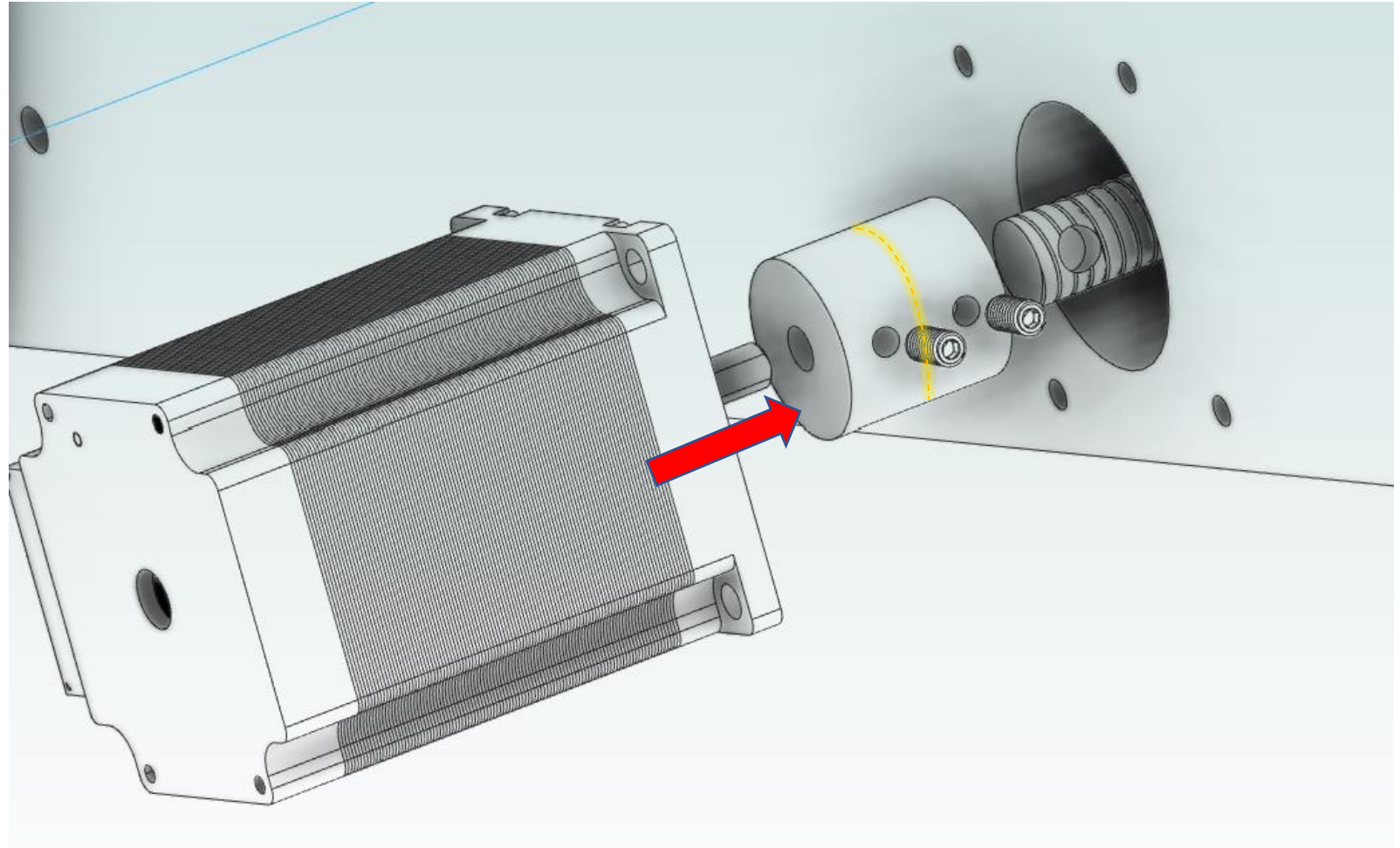

Assembly

Part 2 -

Align the flat side or pocket on the threaded rod with the coupler set screw hole.

Push the motor and coupler onto the threaded rod so the set screw will be centered in the pocket on the threads or the flat side.

Apply blue Loctite or non-permanent thread locker onto the set screw.

Tighten the set screw into the flat side or pocket of the threaded rod using the 3/32" Allen wrench.

-The HD5xx series and SD1xx series will have a pocket milled into the threads of the lead screw.

-Shark HD4 and prior and Piranha FX and XL will have a flat side on the lead screw.

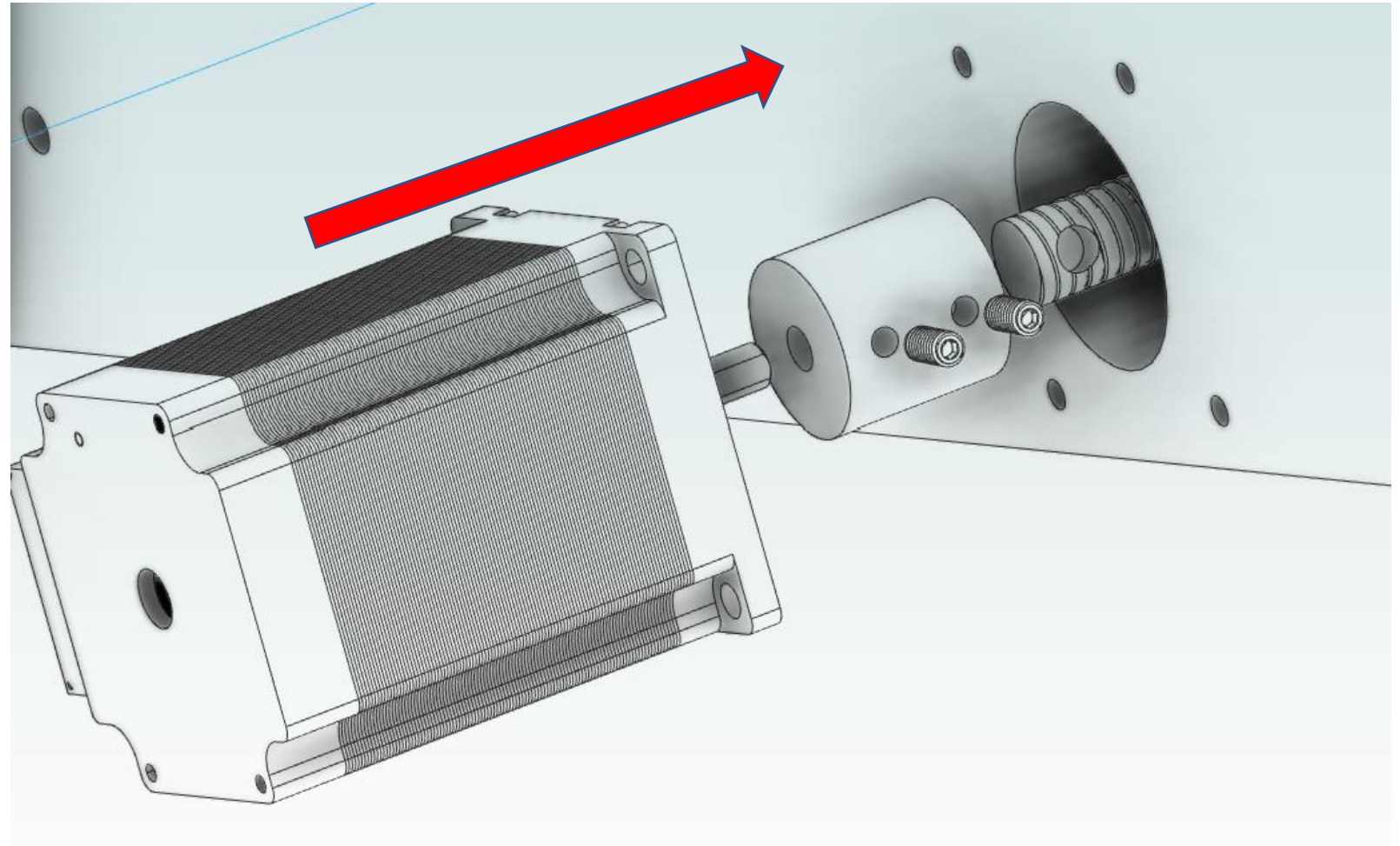

Push the assembled motor, coupler, and threaded rod into the gantry leg.

The opposite side of the threaded rod will seat into a skate bearing in the gantry leg.

Tighten the four machine screws back into place to secure the motor to the gantry leg.

